

B2X™ SERIES



B2X-21H VEHICLE MOUNT HORIZONTAL DRIVE

MID-RANGE 2-STAGE FIRE PUMP

Designed for OEM Fire Apparatus Manufacturers who need a vehicle mounted pump the **WATERAX B2X** is a versatile Mid-Range portable pump that delivers the best performance of its class with minimal operating costs. Unlike other pumps, the **B2X** uses a low maintenance drive belt system that provides efficient and dependable performance.

The **WATERAX B2X-21** pump pairs a reliable high performance Mid-Range 2-stage pump end with a powerful Honda 4-stroke 21 hp engine to achieve pressures of up to 200 PSI (13.8 BAR) and flow rates reaching 300 GPM (1136 L/Min). A strong show of both pressure and volume makes it the ideal pump for vehicle mounted applications dedicated to municipal and wildland urban interface operations.

The **WATERAX** quick release clamp provided on the **B2X** pump provides ease of maintenance without having to disassemble the complete pump unit thus significantly reducing equipment downtime.

Applications

- Vehicle mounted applications
 - Brush trucks
 - Initial attack units
 - Slip-on units
- Booster reel
- 2x 1-1/2" simultaneous attack lines
- 2-1/2" supply line
- Structure protection
- Water transfer
- Boat fire pump

Features and Benefits

- Versatile fire pump offering the firefighting capability, high pressure hose reel, multiple attack lines, and water transfer capabilities.
- Quick release clamp and swappable pump ends for ease of maintenance and minimal equipment downtime.
- Belt drive system for reliable, low maintenance performance.
- Aluminum alloy pump components and anodized parts for lighter weight and greater resistance to corrosion
- Comprehensive user and service manuals
- EPA Certified

SPECIFICATIONS

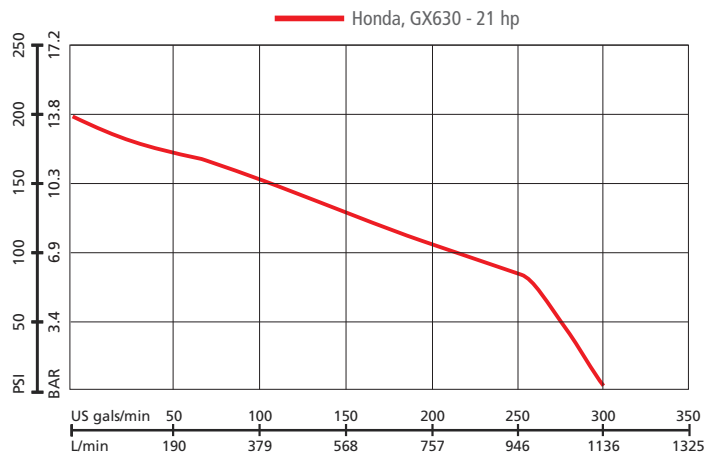

Flow rate at specified pressure

Maximum Pressure: 200 PSI
 Free Flow: 300 US gals/min (1136 L/min)
 Maximum Head: 462' (141 m)

Flow Rate			Pressure	
US GPM	(LPM)	@	PSI	(BAR)
275	(1041)	@	50	(3.4)
215	(814)	@	100	(6.9)
112	(424)	@	150	(10.3)

Engine: Honda, GX630 - 21 hp

HONDA
ENGINES

Pump Specifications:

Type: Detachable 2 stage Centrifugal
 Ratings: ISO 9 and NFPA 1906 Medium Pressure Rating of 50 GPM
 Description: Medium Pressure, Medium Flow, Foam Compatible
 Maximum Allowable Pressure: 400 PSI (27.6 bar)
 Maximum Flow: 300 GPM (1136 lpm)
 Intake: 3" NPT Female/4" Victaulic Combination
 Discharge: 2-1/2" NPT Female/3" Victaulic Combination
 Body & Diffusers: Anodized corrosive resistant aluminum
 Impellers: 4.00" Diameter; Anodized corrosive resistant aluminum
 Pump Shaft: Stainless Steel
 Bearings: Maintenance Free; sealed ball bearing
 Pump Seal: Heat resistant, Maintenance Free
 Clamp: Hand tight quick release clamp (no tools needed)
 Drive Unit: Timing Belt and Pulley; Speed Inserter
 Speed Inserter Position: Horizontal
 Drive Ratio: 1.88: 1
 Color: Red
 Special Feature: The entire pump separates completely from the engine/speed inserter.

Engine Specifications:

Model & Type: Honda, GX630 Series 4-cycle, horizontal shaft, twin cylinder, OHV
 Maximum Power: 20.8 HP (15.5 kW) @ 3600 RPM
 Maximum Torque: 35.6 lb-ft (48.3 Nm) @ 2500 RPM
 Bore & Stroke: 3.07 x 2.83 inches (78 x 72 mm)
 Displacement: 41.98 cubic inches (688 cc)
 Starting System: 12 VDC electric start
 Ignition: Digital CDI with variable ignition timing
 Charging: 17 AMP regulating alternator
 Wiring: Pre-wired for Fast Wire panel connections (panels purchased separately).
 Governor: Mechanical
 Cooling: Air Cooled
 Lubrication: Oil, Full pressure
 Oil Capacity: 2.1 quarts (2.0 liters)
 Fuel Pump: 18 inch lift.
 Emissions: Meets current CARB, EPA, and CE requirements.
 Fuel Type: Gasoline [unleaded, 86 minimum octane, 10% maximum ethanol]
 Fuel Consumption: 1.8 US gals/hr (6.8 liters/hr)
 Muffler: Forestry approved spark arrestor

All features are not available on every model. Please refer to the product selection matrix to select the proper model.

SPECIFICATIONS

Primer Specifications:

Hand Primer Option:	Guzzler, Diaphragm Type; Reliable, Lightweight and Rugged
Intake and Discharge Port Size:	½" Female NPT
Construction:	Aluminum Handle, composite body, buna-n reinforced diaphragm and flapper valves
Lift:	12 feet (3.7 m) [up to approximately 16 feet (4.8 m) with suction hose footvalve]
Head Capacity:	30 ft (9.1 m)
Maximum Pressure:	15 PSI (1.03 bar)
Maximum Service Temp:	150° F (66° C)
Volume per Stroke:	0.44 quart (0.42 liter)
Dimensions (L x W x H):	12-3/4" x 4-1/2" x 4-5/16" (324 x 114 x 110 mm)
Weight:	1.70 lbs (0.77 kg)
	Shipped loose with connection hardware and 6 feet of hose
Electric Primer Option:	12 VDC Piston Type Vacuum Pump
Intake and Discharge Port Size:	3/8" Female NPT
Construction:	Corrosion Resistant Aluminum with Bronze Sleeve and Composite Piston
Max. Current Draw:	105 amps
Lift:	25 feet (7.6 m)
Vacuum:	22 in-Hg
Dimensions:	9" x 4-1/8" x 7-1/2" (229 x 105 x 191 mm)
Weight:	8.1 lbs (3.7 kg)
Vehicle Units:	Shipped loose with mounting plate, hardware, and 6 feet of hose

Frame Specifications:

Vehicle Mount:	Black flat base with tubular horizontal legs. (Provided with industrial grade stud isolators - shipped loose)
----------------	--

Controls Specifications:

Engine supplied controls:	Push/Pull Choke & Throttle lever.
FastWire quick connect:	Loomed engine wire harness (pre-wired to engine) with 8 pin Molex MX150L Industrial Sealed Male Connector. All Vehicle Mounted B2X pumps are equipped with FastWire quick connect engine wire harness for plug & play ease in connecting pump engine, power, and control components such as the WATERAX Control Panels MCP, PMSCP, WCP* Series.
WATERAX Control Panels:	MCP, PMSCP, WCP* Series * Water and/or foam level monitors, electric primer, work light options available.

Note: Refer to the WATERAX Control Panel data sheet and specifications to select a remote mount panel and/or call your WATERAX dealer to customize your own control panel with water and/or foam level monitors, and toggle switches for optional electric primer and work light.

PRODUCT SELECTION

PRODUCT SELECTION MATRIX

		B2X-21H	
STANDARD INCLUSIONS	Primer	Guzzler Hand Primer	-
		Remote Exhaust Primer w/Control Cable PART-763	-
		Exhaust Primer	-
		Electric Package - Electric Primer, LED work light, & Battery	-
	Muffler	Horizontal low tone	S
		Dual B&S low tone	-
		Exhaust primer muffler	-
	Fuel Tank	Integral / 7 US qts (6.6 L)	S
		Integral / 4 US qts (3.8 L) w/ 3-way valve	-
	Controls	Engine Mount Control Panel	-
	Discharge Gauge	0-600 psi, 2-1/2" dial	-
	Check Valve Manifold	B&S 3' CTRL Cable with 8 pin connector (FWC-B-3)	S
FastWire CTRL Cable	Honda GX630 3' CTRL Cable with 8 pin connector (FWC-H-3)	-	
Weight		169 lbs (77 kg)	

OPTIONS & ACCESSORIES

Sold Separately

Controls



VCBLKIT
Vernier Throttle Cable



PMSCP
Panel Mount Standard Control Panel
w/ FastWire CTRL connector.



MCP
Mini Control Panel
w/ FastWire CTRL connector.



WCP
WATERAX Control Panel
w/ FastWire PWR & CTRL connectors.

Primer	Electric Kit	FastWire Cables
--------	--------------	-----------------



GZPRIMERKIT
Guzzler Hand Primer
with hose & valve



BATKIT-66
Deep Cycle Battery Kit
w/ FWP-9 cable



FWC-B-3
3' B&S CTRL Cable
w/ lugs & 8 pin conn.



FWP-20
20' PWR Cable with lugs
& Anderson conn.



EPRIMERKIT
Electric Primer w/ plate,
5' harness & switch



WLIGHTKIT
LED Work Light w/ 5'
harness & toggle switch

FWX-3
3' CTRL Cable Extension
w/ two 8 pin connectors

FWP-9
9' PWR Cable w/ lugs
& Anderson conn.

FWP-3
3' PWR Cable w/ lugs
& Anderson conn.

Fuel Tank	Pump Intake & Discharge Adapters
-----------	----------------------------------



FA-452
Remote Fuel Tank
6.6 US Gallons w/ quick conn.

FA-452-3
Remote Fuel Tank
3.2 US Gallons w/ quick conn.



B2X-CONVKIT
B2XRK1
B2X-PVKIT
ADP-B2X-25N25N
ADP-B2X-30N25N
RED-24255252
RED-24255253

B2 TO B2X CONVERSION KIT
SEAL KIT FOR B-2 & B2X
B2X PRIMER VALVE KIT
ADP KIT B2X,SUC 2.5,DIS 2.5 NH
ADP KIT B2X,SUC 3.0,DIS 2.5 NH
WYE VALVE 2.5NH F X 1.5NPSH M
WYE VALVE 2.5NH F X 1.5NH M

12-401B-NS-TRPD
Fuel Line EPA -
quick conn. to hose 1/4"

12-401B-NS-TRPD
Fuel Line -
quick conn. to SAE 45 Flare

B2X-21H

Length 27.76" (70.5 cm) Width 19.97" (50.72 cm) Height 20.83" (52.9 cm) Weight 169 lbs (77 kg)

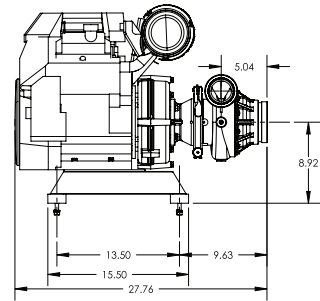
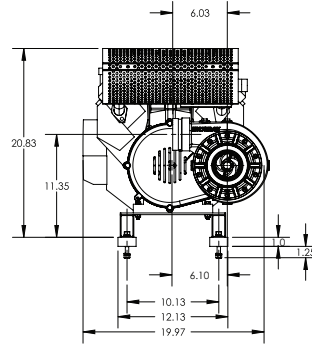
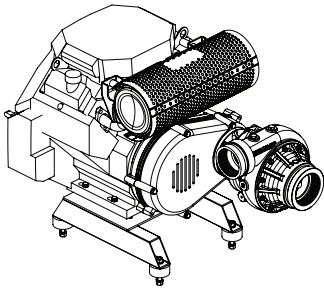



WATERAX Inc.
6635 Henri-Bourassa W.
Montreal, QC H4R 1E1

TF 855-616-1818

T 514-637-1818

F 514-637-3985

info@waterax.com
www.waterax.com

Distributed by:

All information contained in this document including drawings is proprietary to *WATERAX* and may not be copied, reproduced or used in whole or in part without our prior written permission. The information in this document is subject to change without notice. Model displayed with multiple options. Weight and dimensions are approximated and may vary depending on options.