

B2X-18/23 Quick Guide

This Quick Guide shows the basic operation of the WATERAX B2X-18/23 2-stage mid-range pump.

- The WATERAX B2X-18/23 pairs a WATERAX 4-stage pump end with a Briggs & Stratton 18HP or 23HP gasoline engine. For instructions regarding the engine, as well as for oil and fuel recommendations, please refer to the engine manufacturer's manual.
- For detailed instructions on using and troubleshooting your pump, as well as full service and maintenance instructions, refer to our website to download the *B2X Owner's Manual*.
- For full specifications and performance curves, see the *B2X-18/23 Data Sheet*.



Warnings and Safety Precautions

This warning label appears on all WATERAX pumps to identify safety hazards as follows:



READ YOUR ENGINE MANUAL!

Before proceeding further, locate and read the engine manufacturer's manual. It contains very important safety information that **MUST** be read, understood and followed to safeguard you and your equipment from harm, as well as for the proper use and care of your engine. Use only fuel and oil type recommended in the engine manufacturer's manual. Always check oil level in crankcase before use.



WEAR EAR AND EYE PROTECTION.

Always wear eye and ear protection when operating the pump unit. Sound level of the unit: 99 dB(A).



GENERAL WARNINGS:

- Do not operate if mentally or physically fatigued.
- Inspect hoses and piping to avoid burst injuries.
- No modifications and/or alterations may be made to the pump. Any such modifications void the pump warranty and can endanger pump operators.
- Do not operate the pump above the maximum rated pressure. Use only pipe, hose, and fittings rated at or above the maximum pressure rating of the pump or system design.
- Slowly close valves. Use slow close valves wherever possible to safeguard operators and prevent damage from water hammer.
- Dry weight of the unit: 167 lbs (will vary depending on options).



READ THE PUMP OWNER'S MANUAL!

The improper use of this pump could result in serious injuries as well as damage to the unit. Read the *B2X Owner's Manual* before using your B2X pump unit and follow the safety instructions in this Quick Guide.



NEVER RUN THE ENGINE IN A CLOSED OR CONFINED AREA. Exhaust gas contains carbon monoxide which is poisonous to humans. Avoid inhalation of exhaust gas.



REFUEL ENGINE WITH CARE. Gasoline is extremely flammable, and gasoline vapor can explode. Refuel in a well-ventilated area, with the engine stopped.



NEVER TOUCH ANY EXHAUST SYSTEM PARTS WHILE ENGINE IS RUNNING. Always allow enough time, after stopping the unit, for proper cooling of these parts and surrounding areas.

EQUIPMENT DAMAGE PREVENTION:

- Flush the pump with fresh water if the pump has been used to pump salty, brackish, high mineral content water, water containing debris, or foam injected water. Check that debris is cleared before using the pump again.
- Always draft water using a suction hose strainer.

B2X-18/23 Quick Guide

Parts Identification

- A. Priming port
- B. Pump intake (suction)
- C. Pump drain ports (not shown)
- D. Quick release pump clamp
- E. Pump discharge
- F. Low-tone muffler
- G. Fuel pump (not shown)
- H. Fuel valve* (not shown)
- I. Starter key switch** (not shown)
- J. Rewind starter (not shown)
- K. Throttle** (not shown)
- L. Choke (not shown)
- M. Control panel*† (option)
- N. Exhaust primer*‡ (option)
- O. Guzzler primer* (option)

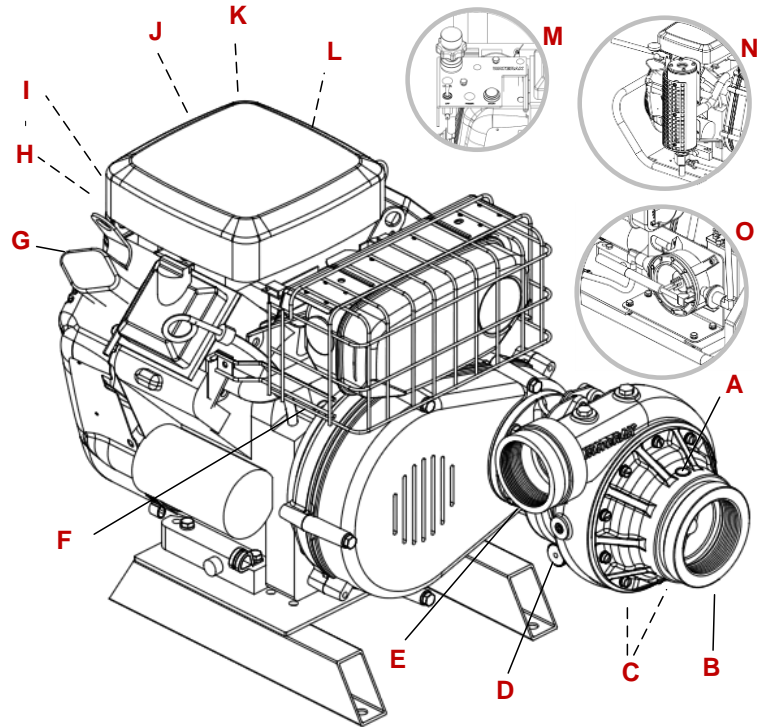

* Denotes optional components.

** Items not available when Control Panel Option is selected.

† Engine mounted control panel shown. Other options are panel mount control panels and skid mount panels.

‡ Replaces low-tone muffler

To operate the B2X-18/23 unit:

1. **Fill fuel tank with recommended fuel grade.**
 - a. For models with an integral fuel tank, fill the tank and securely replace cap.
 - b. For models without an integral fuel tank, fill the external fuel tank and connect fuel supply line to the fuel filter. Pump fuel to fill supply line.

Check oil level (see engine manual).
2. **Connect the suction hose**, using a universal hose coupling wrench to tighten coupling firmly:

Drafting Mode: Connect the strainer or footvalve strainer to the male end of the suction hose and then connect the female end to the pump intake. NOTE: If desired, a suction hose with a footvalve may be filled at this time to shorten pump priming.

Flooded Suction Mode: Connect female end of suction hose to pump intake and connect male end to hydrant or other supply.

 - a. Slowly open the pump inlet valves allowing the water into the pump body.
 - b. Slowly open the discharge valves and priming valves to allow for entrapped air in the piping to escape.
 - c. Once all the air has escaped, slowly close any discharge and/or drain valves so that the unit may be started.
3. **Connect discharge hose, nozzles, etc., to pump**, and tighten firmly with coupling wrench.

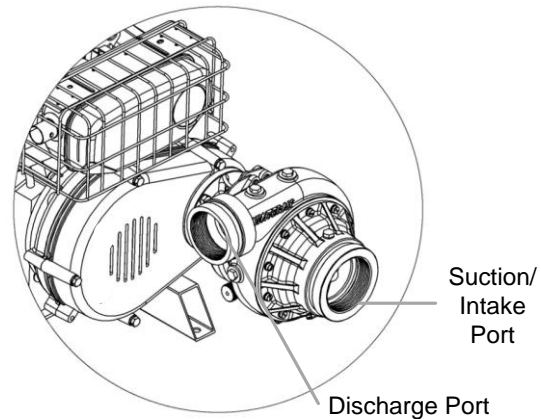

- ! **DO NOT** allow the strainer to rest on bottom of lake or riverbed. Check strainer frequently to make sure that it is not clogged with moss, leaves, etc.
 - ! **DO NOT** lift strainer from water while the pump is operating. Use a rope or other means to keep strainer at proper height, approximately 1 foot (30 cm) below water surface. If strainer is too close to the water surface, it will draw air and pump may lose prime.

4. Prime the pump.

Check that all drains, discharge valves, or any auxiliary valves are closed before priming the pump. Open the priming ball valve (located between the pump and the primer).

Guzzler Priming: If equipped with a Guzzler primer, follow the hand pump manufacturer's operation instructions. Pump until water is drawn into the pump.

Electric Priming: See instructions for your electric primer. Note that most electric primer motors are intended to be used only a short duration (about 20 seconds). If pump fails to prime, see the *B2X Owner's Manual* for troubleshooting tips.

Close the priming valve after priming. Failure to close the priming valve could cause the pump to lose prime or water to be pumped through the priming system.

Exhaust Priming: See Step 6.

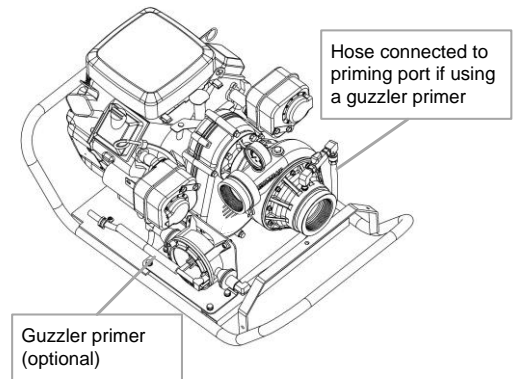

5. Start the engine.

- With all valves closed, turn the on/off ignition key or switch (if equipped with a Control Panel) to the "ON" position.
- Open fuel valve.
- Close/engage choke, if engine is cold.
- Increase throttle past the idle position.
- Start the engine using the key switch or the start button. Hold until engine starts. **DO NOT HOLD** for more than 5 seconds. If starting using the rewind starter, ensure that the key switch or ignition switch (if equipped with a Control Panel) is on the "ON" position. Give starter rope a quick steady pull until engine starts.
- Open/disengage choke.
- Allow the engine to warm up for at least 2 minutes before using full throttle.

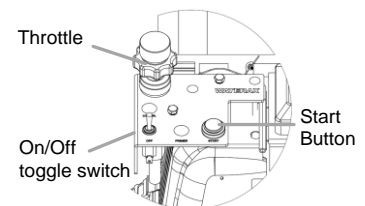

Engine Mount Control Panel (optional)

6. Engage the exhaust primer.

- Open priming valve (located off the top port of the pump intake).
- Adjust the THROTTLE to the full speed position.
- Close and press down firmly on muffler-lever-handle or pull priming knob (if supplied with a panel mount control panel) until a solid stream of water flows from priming ejector.
- Close the priming valve** and re-open the muffler-lever-handle/butterfly valve. The check valve will open automatically under the water pressure when priming occurs.
- Slowly** open a discharge valve to validate that the pump has been primed. If pressure does not build in the discharge hose, the pump has not been fully primed. The valve should be closed and the pump primed again. Continue this process until the pump has been fully primed.
- Reduce throttle setting and allow engine to warm up for at least 2 minutes before using full throttle.

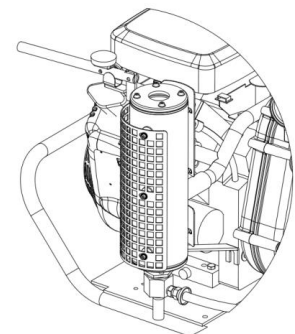

Exhaust Primer (optional)

7. Discharge water.

Once the pump is primed, and with the engine running, you can begin to discharge water.

- If pressure does not build in the discharge hose, the pump has not been fully primed. The discharge valve should be closed and the pump primed again.
- Adjust the pump performance by throttling the engine up or down, or opening or closing discharge valves at various positions, or any combination of the two

! **DO NOT** leave the pump running with all the discharge valves closed for more than one minute, or else the pump may overheat and become damaged. To avoid this, a recirculation line (if provided) should be opened or a discharge line left slightly open to allow fresh water to continue to enter the pump.

B2X-18/23 Quick Guide

To shut down and store the B2X-18/23 unit:

- 1. Shut down the pump.**
 - a. Gradually reduce the engine speed.
 - b. Whenever the unit has been run at full throttle for most of the operation, allow the valves to remain slightly open and run the engine at idle for approximately 2 minutes before shutting down the unit.
 - c. If the unit is to be stored, move the fuel valve lever to the OFF position and wait for the engine to stop. Otherwise, set the ignition switch to the OFF position to shut down the engine.
 - d. Close off the hydrant/supply to the pump.
 - e. Open all valves to relieve any pressure left in the system.
- 2. Check and store the pump.**
 - a. If the pump was last run with foam or water that is salty, brackish or high in mineral content, flush the pump with fresh water for a minimum of 2 minutes or until the water is clear.
 - b. After the unit has cooled down, check all fluid levels and add as needed.
 - c. Completely drain the pump of all water.
 - d. Break down and store all equipment as outlined by the apparatus or department procedures.
 - e. Visually inspect the pump end. Clean any dirt or debris from the pump unit. If necessary, a mild soap and water solution can be used. Note and report any performance irregularities or any abnormal mechanical sounds.
 - f. Close all valves and plug all openings.
 - g. Follow any other product, component, apparatus, and departmental procedures and/or guidelines before placing the unit in storage. Make sure all necessary tools, spares, and accessories are with the pump.

To operate the B2X-18/23 unit in cold weather:

- The pump can be run in below freezing temperatures if certain precautions are taken to avoid the formation of ice in the pump.
- After priming the pump, the unit should be run at low speed for a short period of time to allow all components to warm up before continuing with the remaining operating procedures.
- Unless wrapped in a heater, drain the pump of all water if it is stopped for any length of time. The engine/drive unit should be turned over a few revolutions to make sure all water has been removed from the pump. Drain the pump priming line if a primer has been used.
- After use, drain the pump, manifolds, and lines of all water. You can also pour some antifreeze into the pump and circulate it through the pump and plumbing system.

Warranty, Service and Support

Product and service documentation such as tech notes, data sheets, manuals and information on the limited warranty provided on products manufactured by *WATERAX* can be found on our Web site at: www.waterax.com

WATERAX Inc.

6635 Henri-Bourassa W.
Montreal, QC H4R 1E1
Tel.: (855) 616-1818
(514) 637-1818
Fax: (514) 637-3985
E-mail: info@waterax.com